

SFM-AT350

solukon



The SFM-AT350 can be used to clean parts produced on all additive manufacturing systems.

Compact depowdering unit for powder removal of metal laser-melted parts

The SFM-AT350 cleans metal laser-melted parts within a sealed process chamber, with targeted vibration and automated two-axis rotation.

Through programmable rotation of the parts, including the build plate in two axes, metal powder is also removed from complex voids and support structures.

After the automated cleaning program, manual cleaning with compressed air or inert gas is possible via glove ports.

The depowdering system is based on the unique Solukon Smart Powder Recuperation technology SPR®.

[solukon.de](https://www.solukon.de)

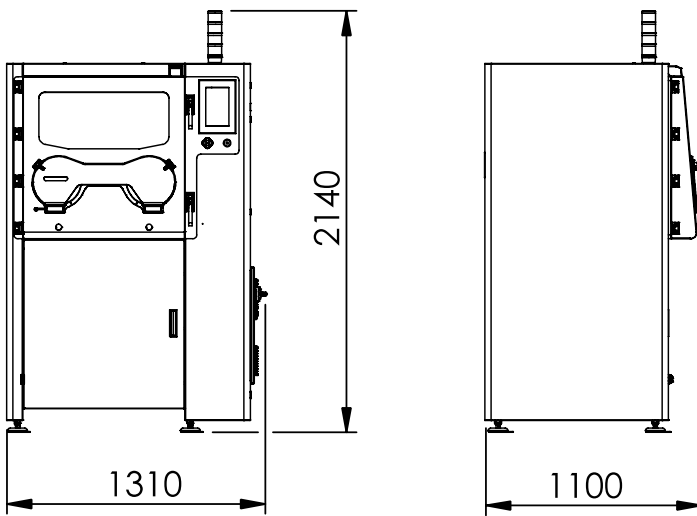
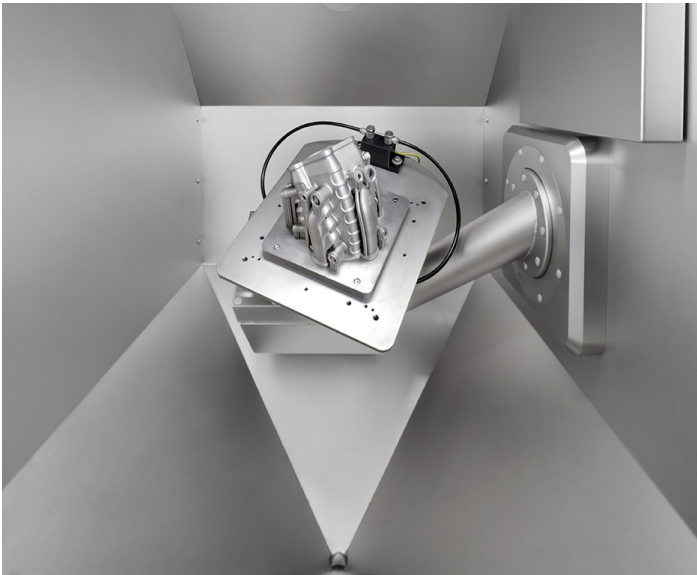

System specifications

Installation space (W x D x H)	2,300 x 2,300 x 2,300 mm
Weight	420 kg
Mains voltage / frequency	400 / 50 - 60 V / Hz
Power consumption	1.0 kW
Power supply	16 A

Compressed air specifications

Working pressure	6 bar
Consumption	max. 300 l/min

Inert gas specifications*

Working pressure	6 bar
Consumption	max. 400 l/min

* only with inert gas infusion option

Part spectrum

- material: aluminum-, steel-, titan- or copper alloy
- weight: up to 60 kg
- dimensions: up to 350 x 350 x 420 mm³

Basic features

- automated 2-axis rotation device
- endless rotatable turntable
- pneumatic connections for manual air cleaning tools
- powder lock with special container
- vibration mechanism with wide frequency range

Options

- dust removal for non-reactive materials
- inert gas infusion for reactive materials (ATEX)
- programmable knocker
- OPC UA interface
- Digital Factory Tool

Advantages

- certified explosion protection
- high degree of protection from harmful dusts
- fast and economic part cleaning
- comfortable part handling
- qualifiable and reproducible cleaning results